

# THERMOCOUPLE WITH STRAIGHT THERMOWELL ADJUSTABLE COMPRESSION FITTING & CABLE

**T-504**

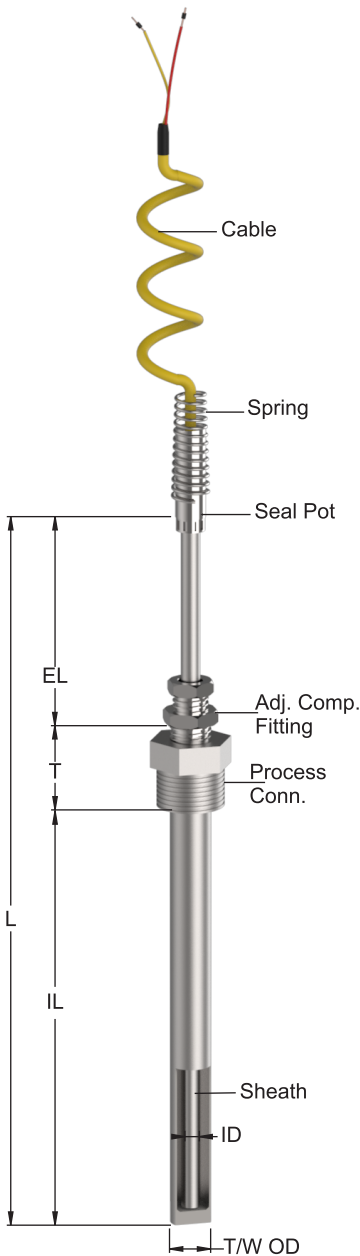

Thermocouple Element

Sheath "OD"

Sheath Material

Junction Style

Thermowell "OD" (mm)

Thermowell ID (mm)

Thermowell Material

Process Connection

Adj. Comp. Fitting

Length of "T" (mm)

Insertion Length (I.L.) (mm)

Extension Length (E.L.) (mm)

Nominal Length of T/C (L) (mm)

Type of Cable

Cable Length (inMtr.)

Calibration Standard

Type of T/C	Description
K	Chromel/Alumel
J	Iron/Constantan
N	Nicrosil-Nisil
T	Copper/Constantan
E	Chromel/Constantan
Other	Consult Factory
Ex. :	If Simplex - K Duplex - KK

1	Ø1mm
1.5	Ø1.5mm
3	Ø3mm
4.5	Ø4.5mm
6	Ø6mm
8	Ø8mm
Other	Consult Factory

316	SS 316
310	SS 310
600	Inconel-600
Other	Consult Factory

GN	Grounded Rounded Tip
UN	Ungrounded Rounded Tip

316	SS 316
310	SS 310
304	SS 304
600	Inconel-600
800	Inconel-800
446	HRS-446
Other	Consult Factory

Threads	1/4"
	1/2"
	3/8"
	3/4"
	1"
	2"
B.S.P. / N.P.T.	1 1/4"
	1 1/2"
	2"
M-Thread	M20X1.5, M18X1.5, M33X2, M27X2
Other	Consult Factory

A	Teflon/Teflon Insulated Flexible Cable
B	Teflon Insulated & SS Braided Flexible Cable
C	FG/FG Insulated Flexible Cable
D	PVC/PVC Insulated Flexible Cable
E	FG/FG/Insulated/SS Braided
Other	Consult Factory

A	ANSI 96.1
D	DIN
I	IEC